

SpeedTube™

SpeedTube Operations Quick Reference Manual

Precision Planting®

Contents

SpeedTube™ Setup	3
SpeedTube™ Operation	3
Vacuum Setting.....	3
Swath Calibration	3
SpeedTube™ Cover, Housing, and Belt Removal	4
SpeedTube Crop Change	7
Annual Maintenance	8

SpeedTube™ Setup

SpeedTube is automatically detected by the 20/20 SeedSense monitor and requires no specific setup. Simply plug the SpeedTube harness into the SpeedTube module and the SpeedTube will be ready for operation after initial updates.

SpeedTube™ Operation

SpeedTubes will operate anytime the Master Plant or a single Section Plant switch is active on the Cab Control Module. If the planter is not moving (lifted or lowered), SpeedTubes will operate at a minimum belt speed. To deactivate SpeedTube operation, the Master Plant and all three Section Plant switches must be off as shown below in figure A.

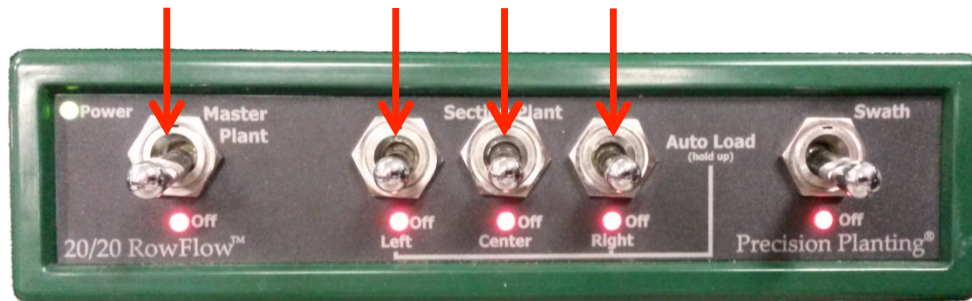

Figure A

Vacuum Setting

Increased vacuum is sometimes necessary when operating SpeedTube at higher speeds. This will reduce the likelihood that seeds will drop off the disk due to rough ride before reaching the feeder wheels.

Swath Calibration

Swath “Run Cal” cannot be performed with SpeedTube installed. Operators should start with the default value for both “Start Seeding Delay”, “Stop Seeding Delay”, and “Calibration Meter Speed”. Once you have begun to plant, dig for seeds and make manual adjustments to the “Start and Stop Seeding Delay” values if needed. Confirm GPS offsets are correct before adjusting “Start and Stop Seeding Delay” values.

SpeedTube™ Cover and Belt Removal

Note: The belt cover can be removed to gain access to the belt and other internal components for inspection, removal, and cleaning.

Step 1

Remove the sensor transmitter using the hand knob. Move the sensor to the side. Refer to figure 1-1.

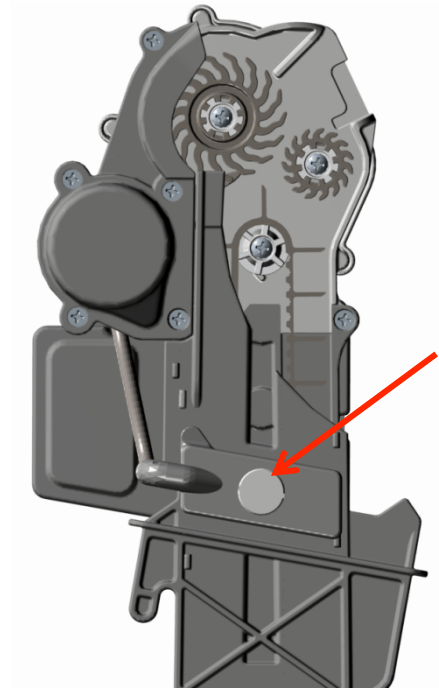

Figure 1-1

Step 2

Remove the SpeedTube belt cover. Push up on the belt cover near the sensor removed in step 1, while simultaneously releasing the lower cover retaining tab. Rotate the cover away from the SpeedTube belt housing. Refer to figure 1-2a and 1-2b.

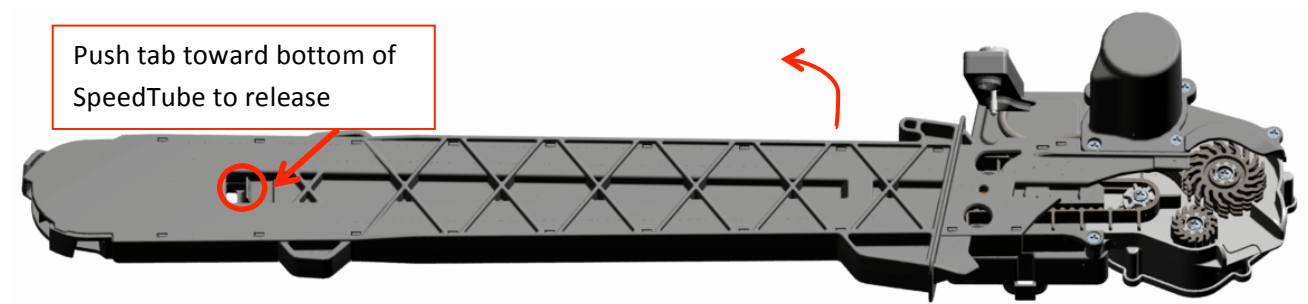

Figure 1-2a

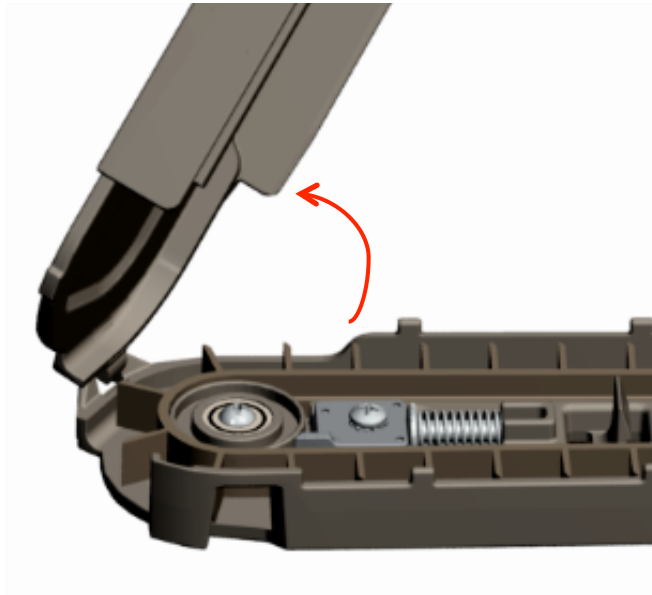

Figure 1-2b

Step 3

Remove the belt by rotating it by hand and rolling it off the bottom idler pulley. Remove from the top drive pulley.

Step 4

Re-install the belt by placing it around the top drive pulley. Ensure it is fully seated. Rotate the belt by hand and roll it onto the bottom idler pulley. Rotate the belt back and forth to check alignment and smooth operation.

Note: When Re-installing the belt, take notice of the flight orientation. Reference the diagram molded into the SpeedTube housing for correct orientation. Refer to figure 1-4.

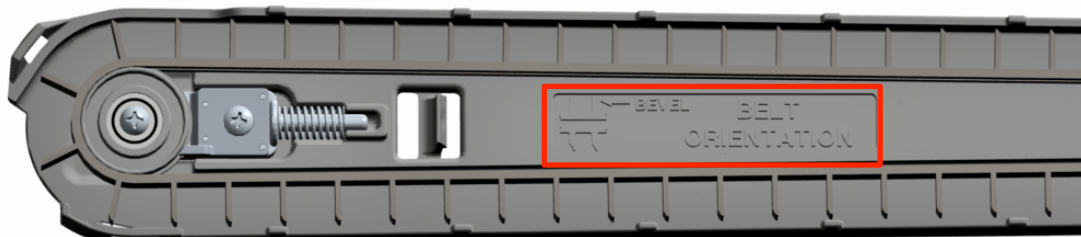

Figure 1-4

Step 5

To re-set the tension for the new belt, loosen the tension bracket retaining screw and ensure the bracket is free from debris and can move freely. Refer to figure 1-5.

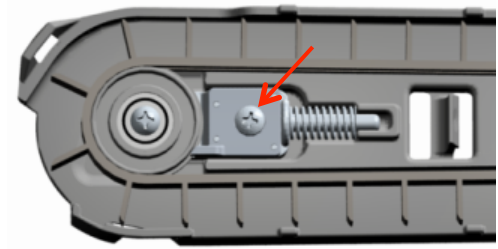

Figure 1-5

Step 6

Roll the belt back and forth by hand. The coil spring will provide the appropriate tension to the belt. Re-tighten the tension bracket retaining screw.

Step 7

Re-install the belt cover. Confirm the hook on the bottom of the cover is inserted in the latch on the belt housing as shown in figure 1-7. Press the cover down around the lower retaining clip. A “click” should be heard, confirming the cover is secured to the housing. Re-install the sensor.

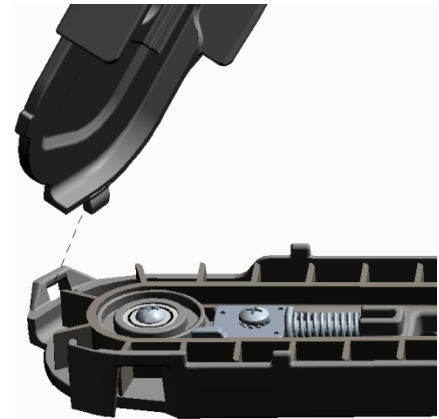

Figure 1-7

SpeedTube Crop Change (Corn to Soybeans)

Note: Meter crop kits will also need to be changed when switching crops.

Step 1

Install the soybean deflector by snapping it into the cavity on the gearbox housing. The small feeder wheel will stay installed. Refer to figure 2-1.

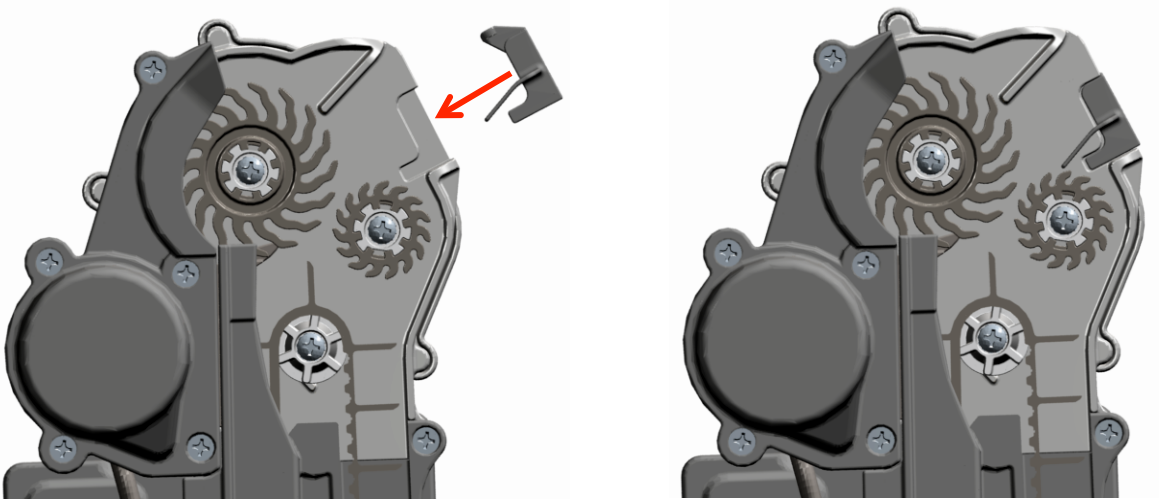

Figure 2-1

Step 2

To switch back to corn, simply remove the soybean deflector. Pull out and away on the rear tab. Refer to figure 2-2.

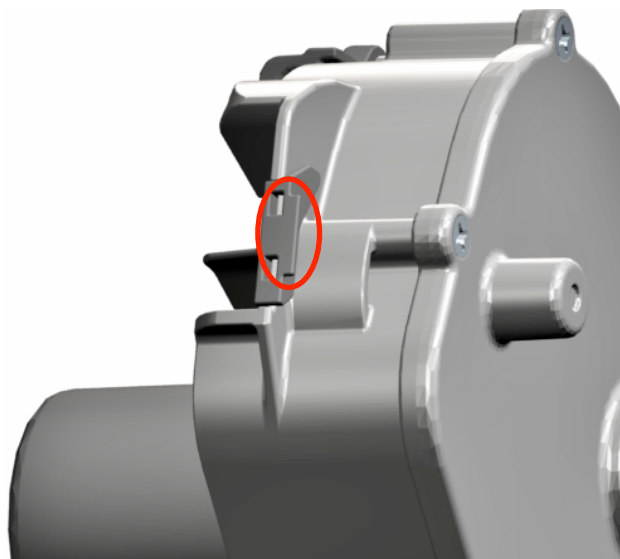

Figure 2-2

Annual Maintenance

Check these items on an annual basis to maintain optimum performance.

- Remove belt from each SpeedTube during off season.
- Reset belt tension before next planting season.
- Check feeder wheels for wear and replace as necessary.
- Inspect overall SpeedTube for any damage or increased wear (housing, sensor lenses, belt pulleys, etc.)
- Check opening disks and guards for accelerated wear. It is best practice to replace guard when replacing opening disks.
- If power washing the planter at end of season, it is recommended to first remove SpeedTubes. Compressed air or lower pressure water is recommended for cleaning SpeedTubes.
- Check row unit for any loose hardware, specifically parallel arm fasteners.

For more details on SpeedTube™, refer to the complete SpeedTube Operators Manual (955424) available at <http://cloud.precisionplanting.com/pubs>.